



Manutenção de Equipamentos

CF 2

Excêntrico

CF 2



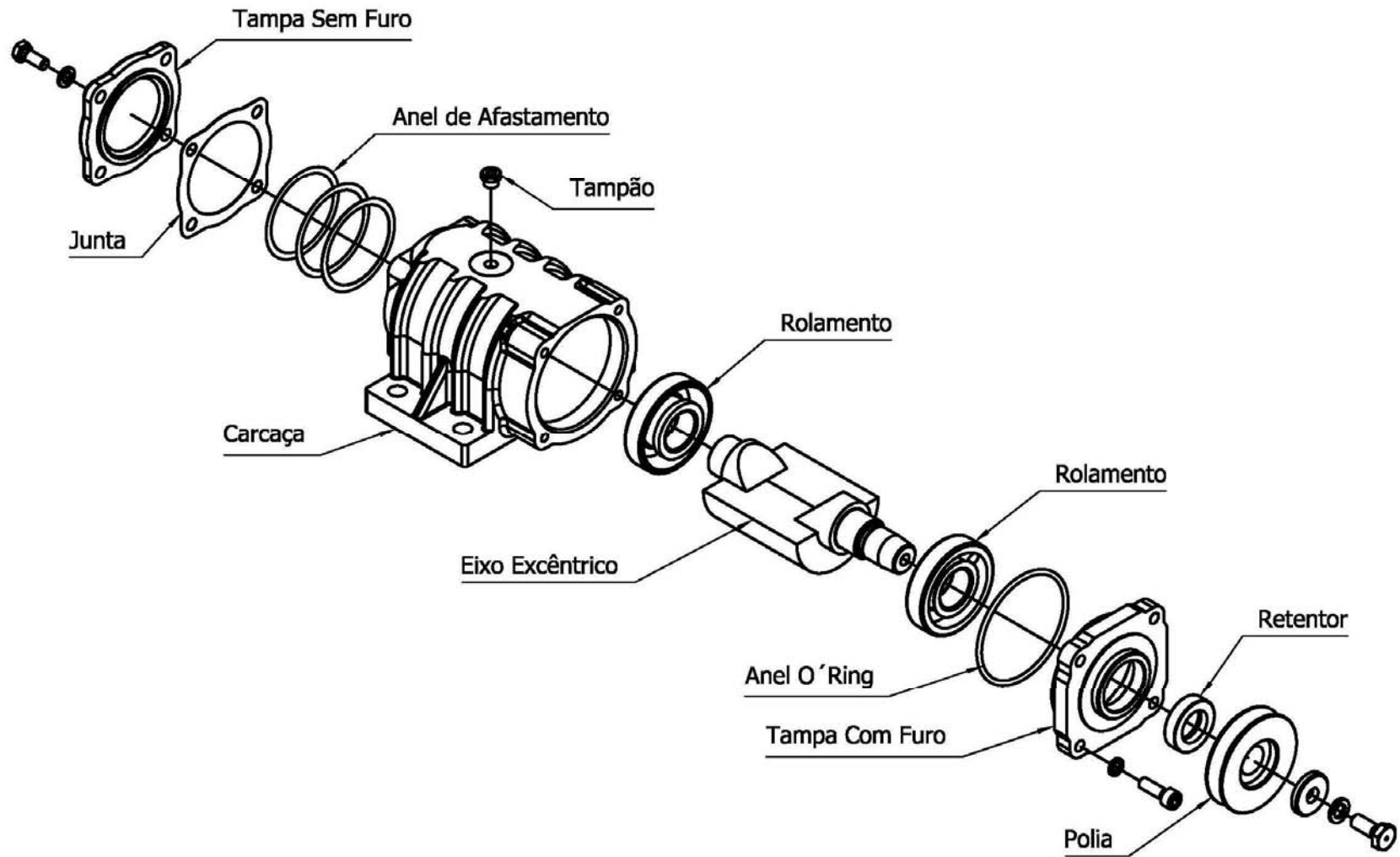

CF 2 - Desmontagem

Soltar os Parafusos (2) e desmontar a Proteção da Polia (1).

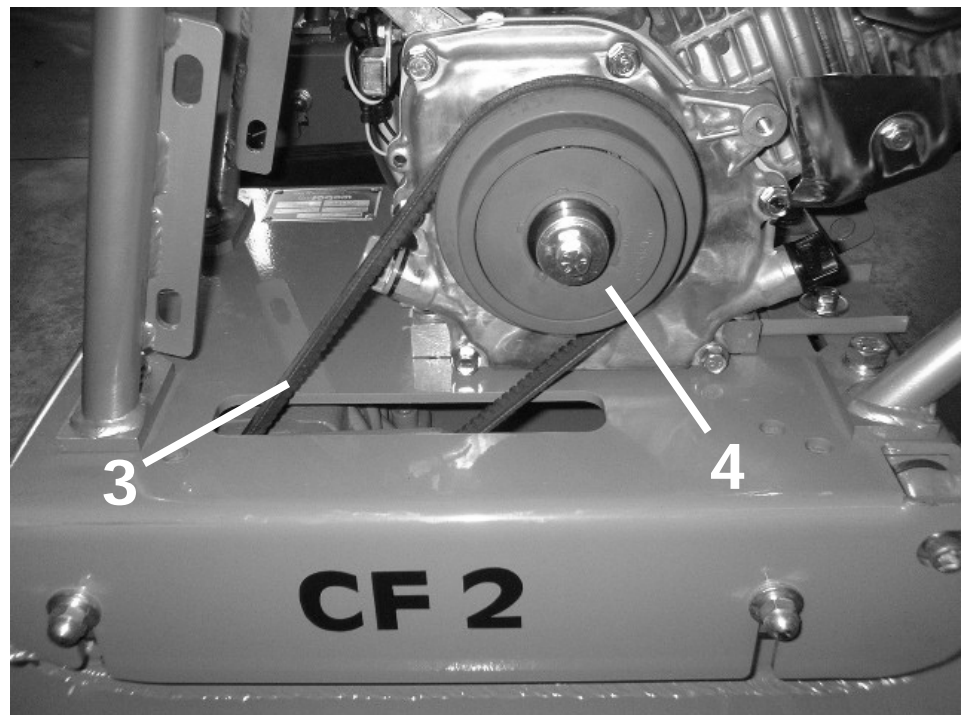
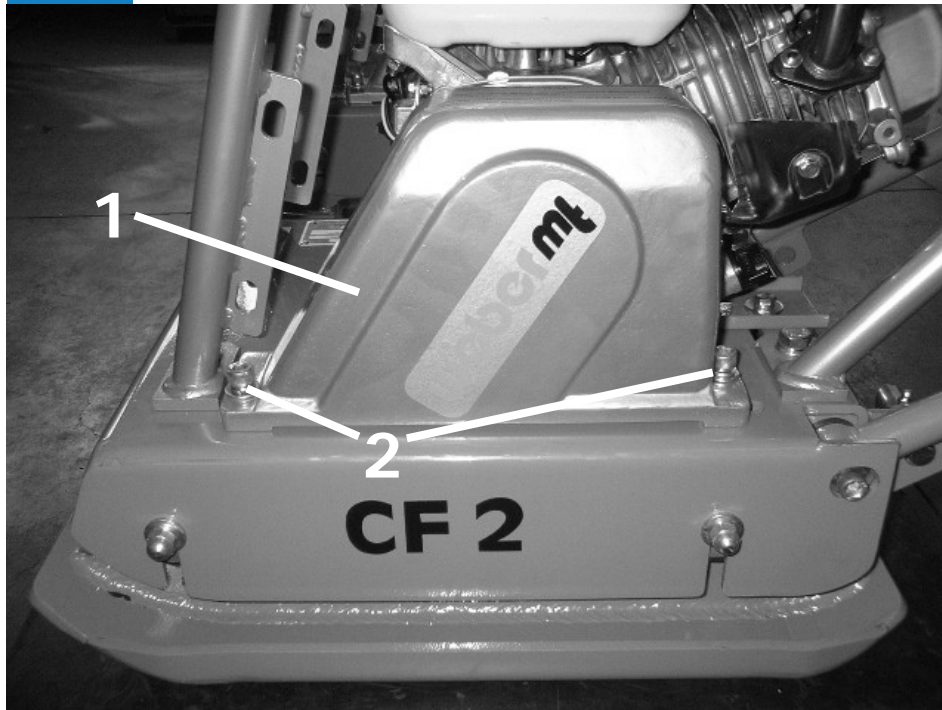

Desmontar a Correia (3) da Embreagem (4).

CF 2 - Desmontagem

Soltar as 4 Porcas (1) nas laterais do Console (2). Retirar a Console (2) de cima da Base (3).

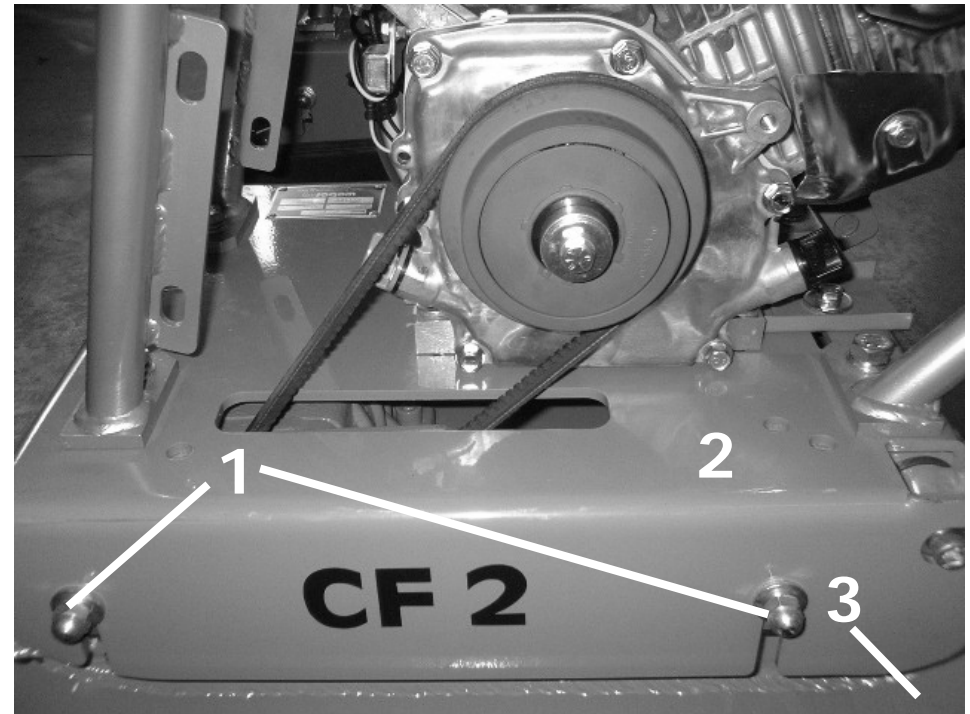

CF 2 - Desmontagem

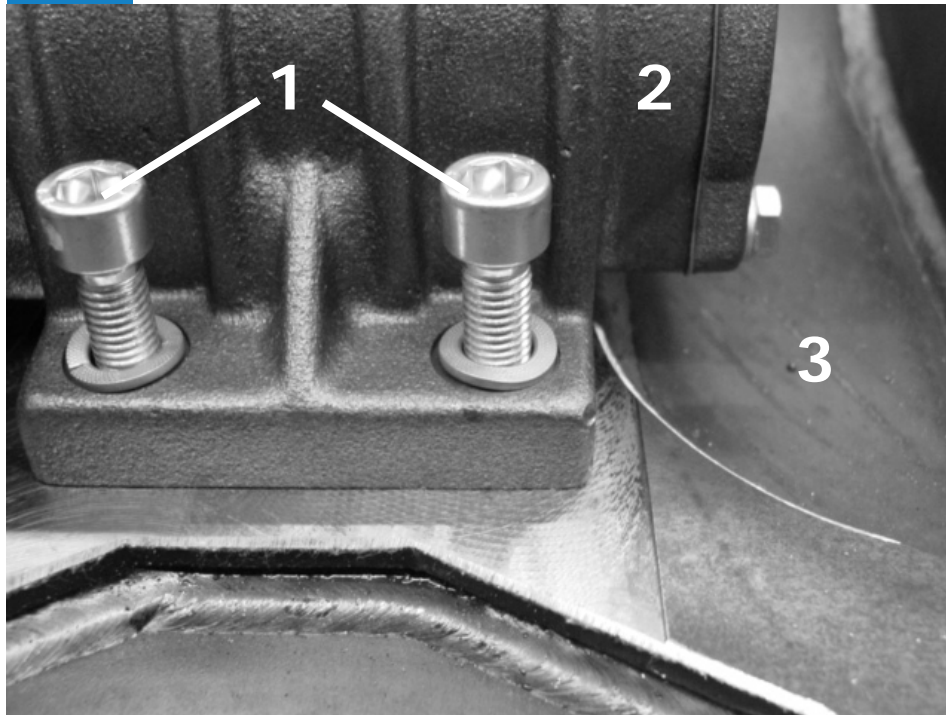

Soltar os 4 Parafusos (1) que prendem o Conjunto Excêntrico (2) na Base (3).

Retirar o Conjunto Excêntrico (1) da Base (2).

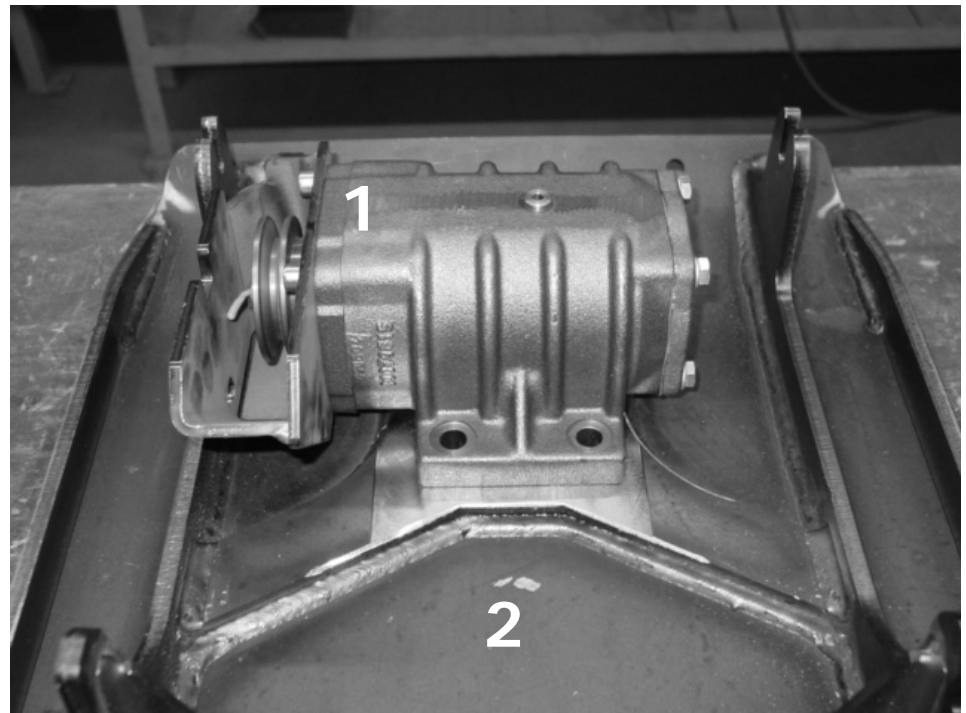

CF 2 - Desmontagem

Retirar o Tampão de Óleo (1).

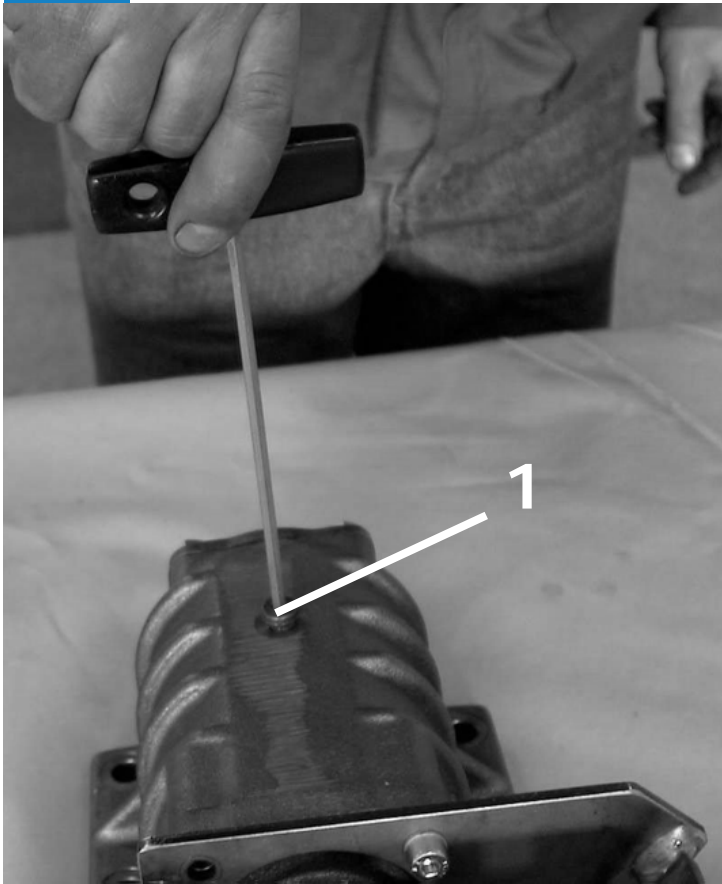

Retirar todo o óleo do
Conjunto Excêntrico (1).



CF 2 - Desmontagem

Colocar o Conjunto Excêntrico na vertical e soltar os 4 Parafusos (1) que prendem a Proteção da Polia (2).

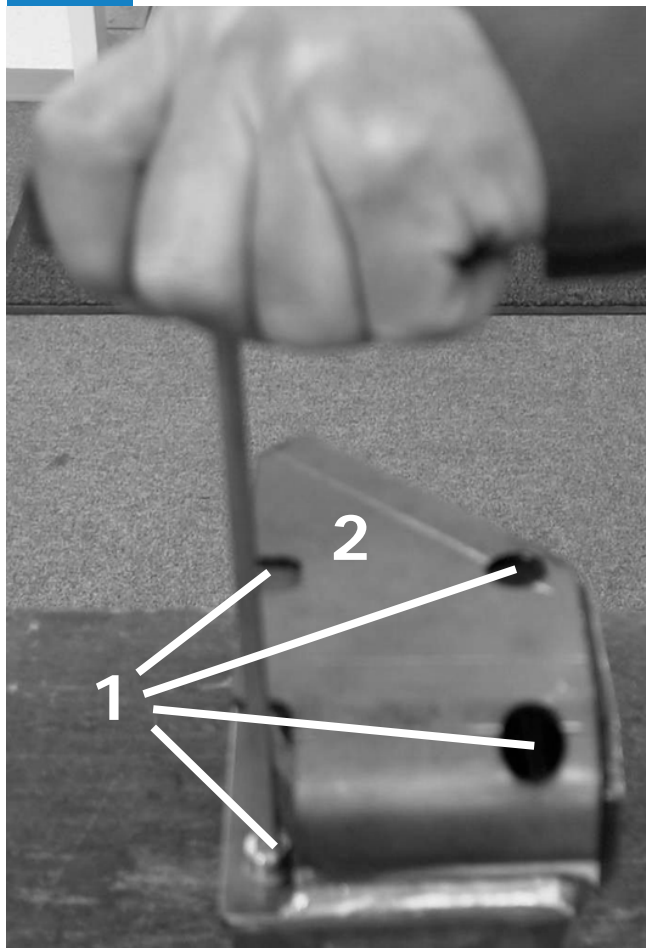

Desmontar a Proteção da Polia (1).



CF 2 - Desmontagem

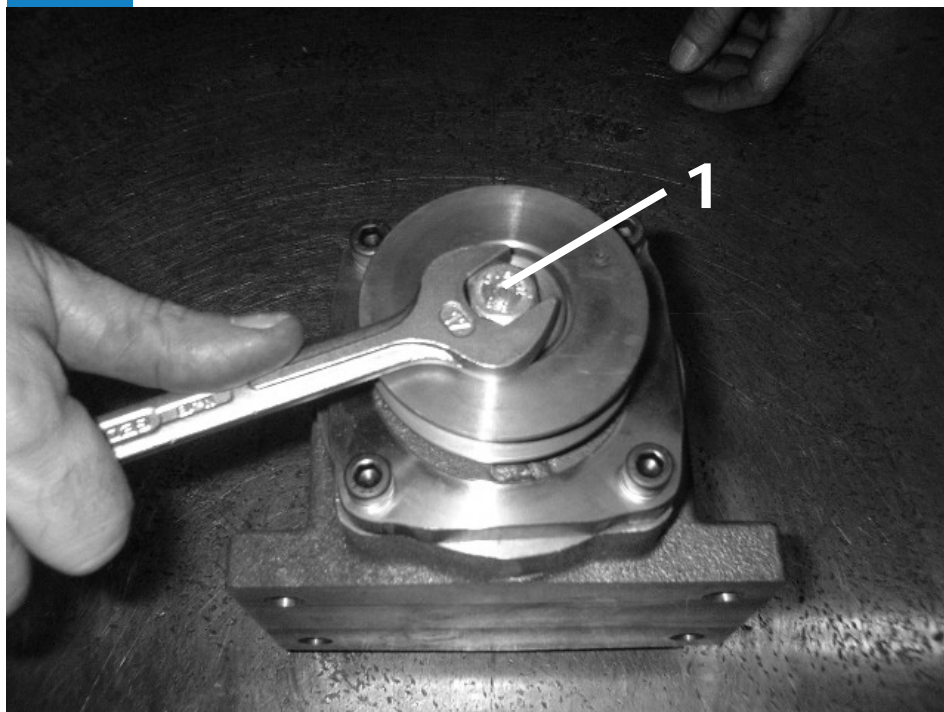

Soltar o Parafuso (1) que prende a Polia do Excêntrico.

Desmontar a Polia do Excêntrico (1) utilizando um Sacador de Polias (2).

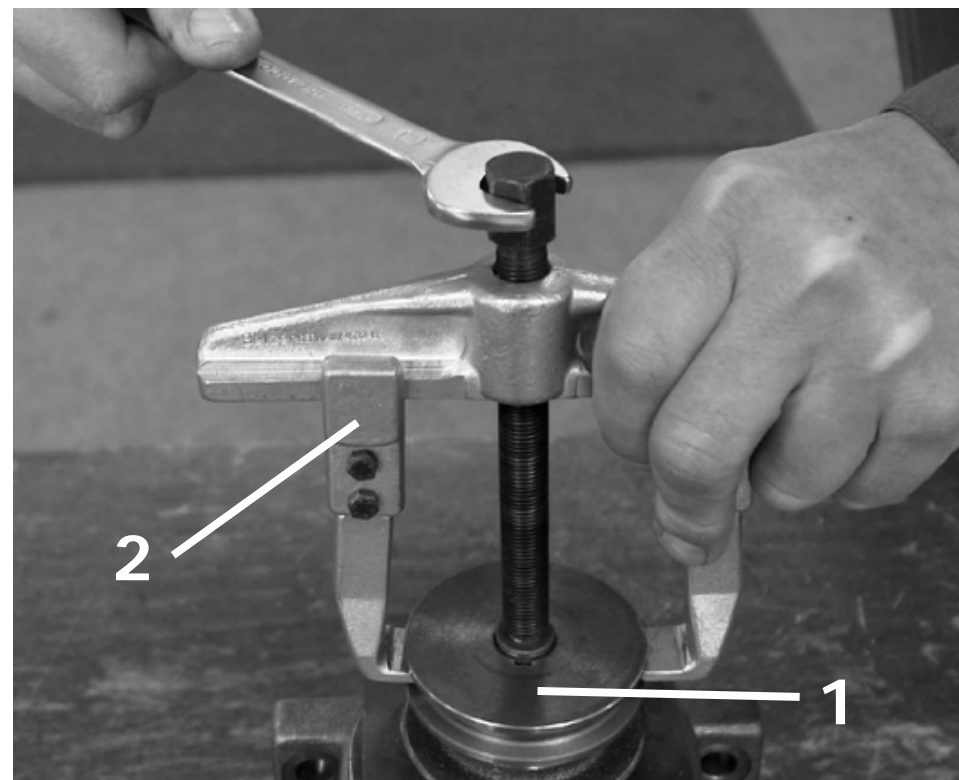

CF 2 - Desmontagem

Desmontar a Tampa com Furo conforme demonstrado nas figuras abaixo.

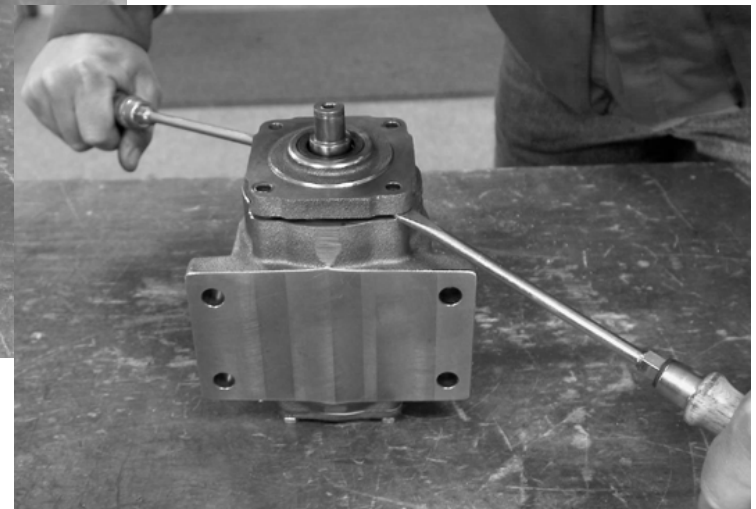
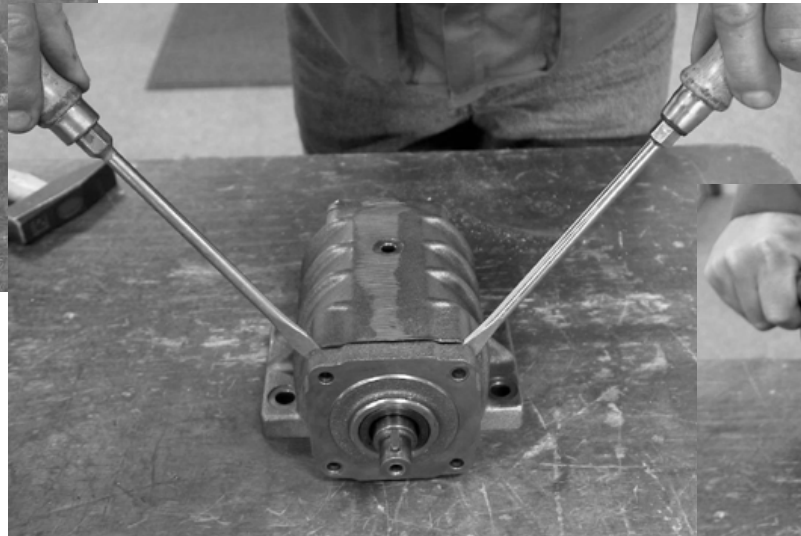
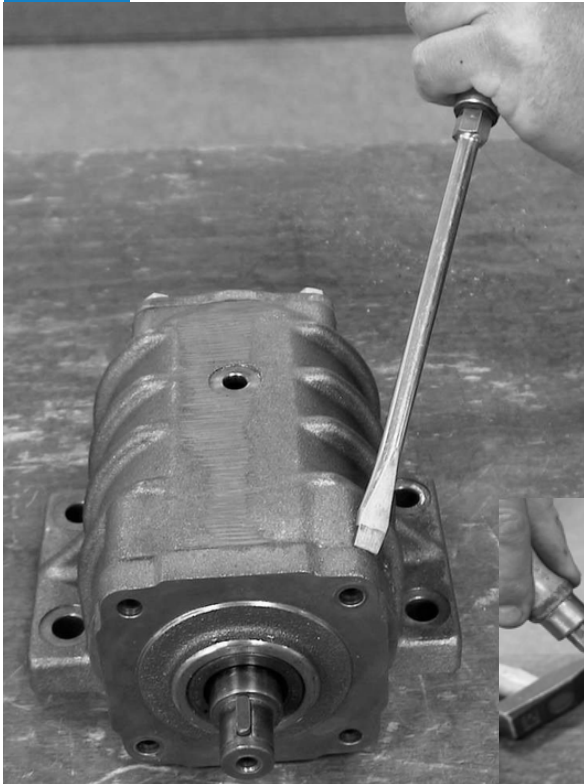

CF 2 - Desmontagem

Retirar o Eixo Excêntrico (1)
de dentro da Carcaça (2).

- 1 – Carcaça
- 2 – Tampa Com Furo
- 3 – Eixo Excêntrico



CF 2 - Desmontagem

Soltar os 4 Parafusos (1) que prendem a Tampa Sem Furo (2). Desmontar a Tampa Sem Furo.

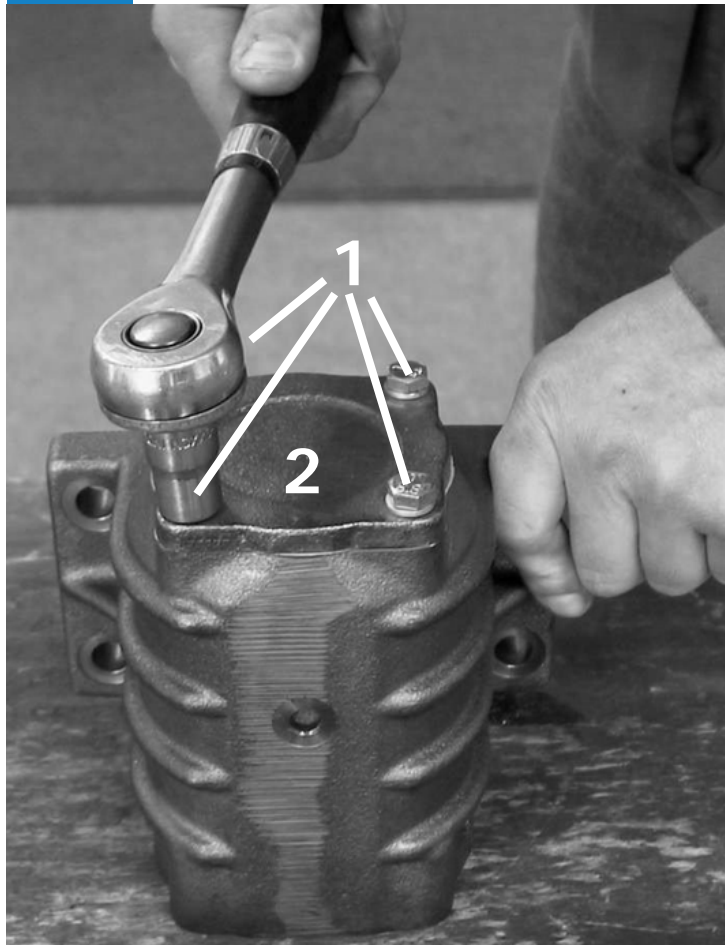

- 1 – Carcaça
- 2 – Pista Externa do Rolamento
- 3 – Tampa Sem Furo
- 4 – Junta de Vedação
- 5 – Anel de Afastamento



CF 2 - Desmontagem

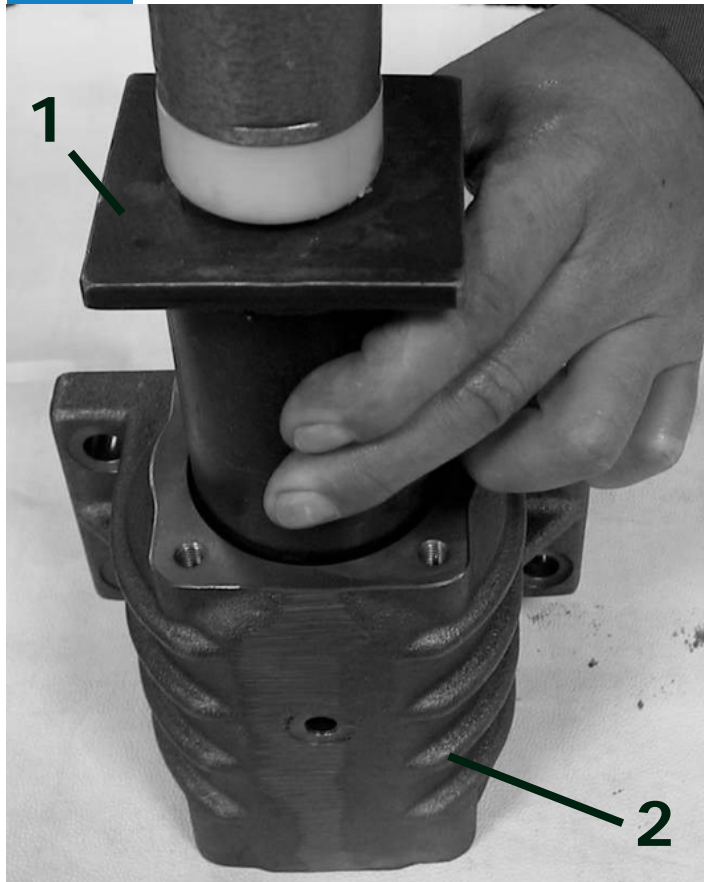

Com uma ferramenta apropriada (1) desmontar a Pista Externa do Rolamento da Carcaça (2).

Com uma ferramenta apropriada (2) desmontar a Pista Externa do Rolamento (1) da Tampa Com Furo (3).

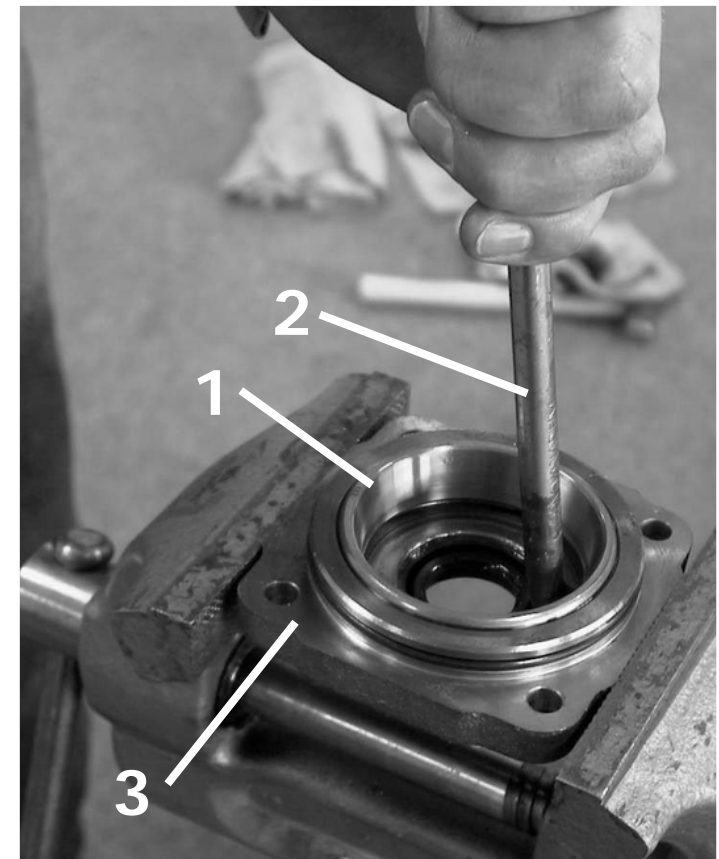

CF 2 - Desmontagem

Desmontar o Retentor (1)
da Tampa Com Furo (2).

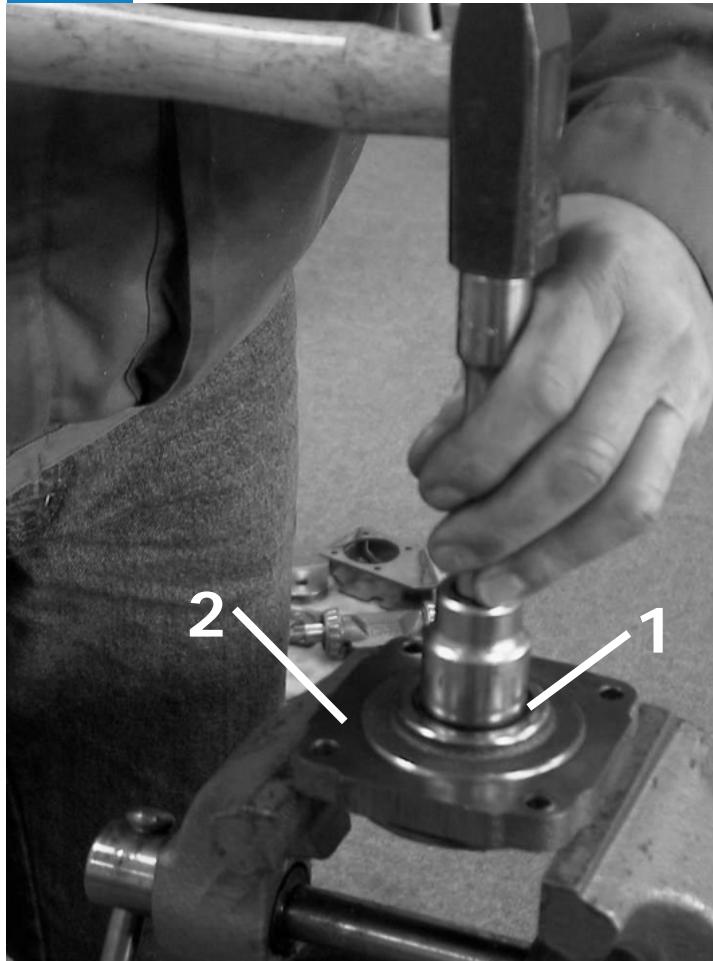

Prender o Eixo Excêntrico (1)
em um Torno de Bancada.
Desmontar o Rolamento (2) com
um Sacador de Rolamentos (3).

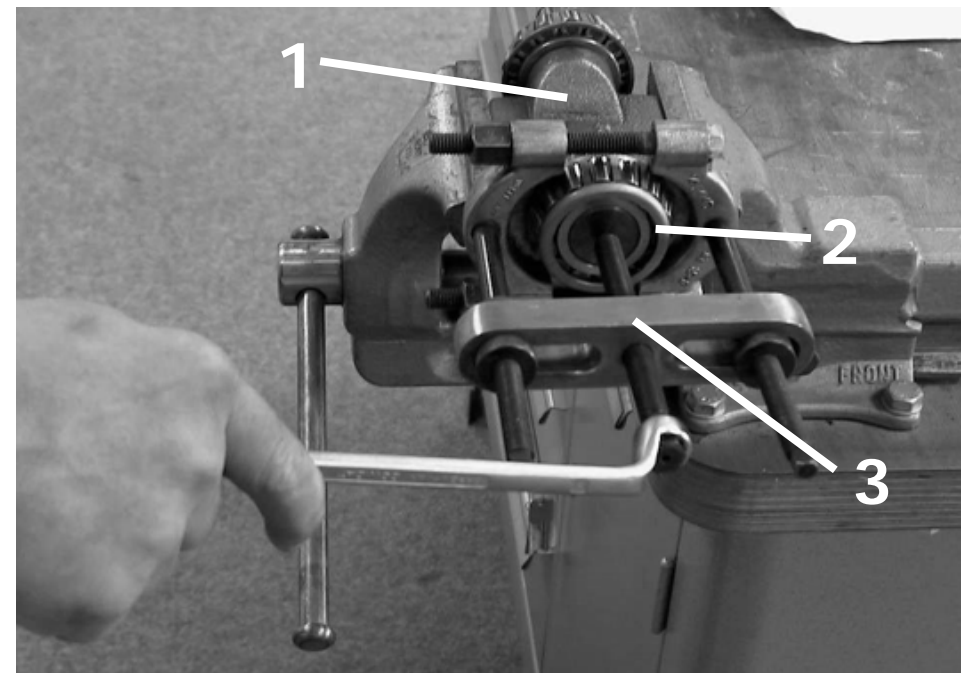

CF 2 - Montagem

Montar a Pista Externa do Rolamento (1) na Carcaça do Excêntrico (2).

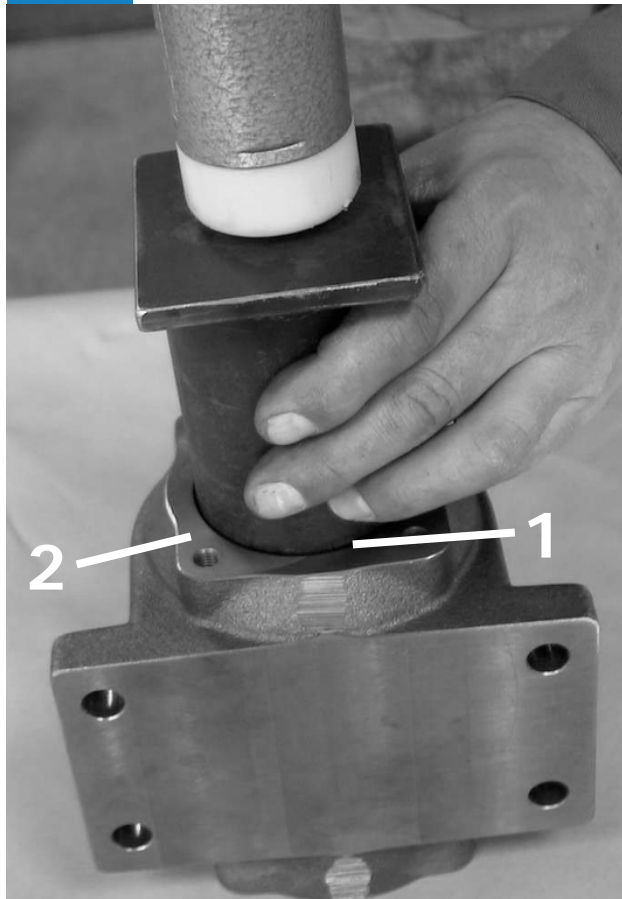

Montar a Pista Externa do Rolamento (1) na Tampa Com Furo (2).

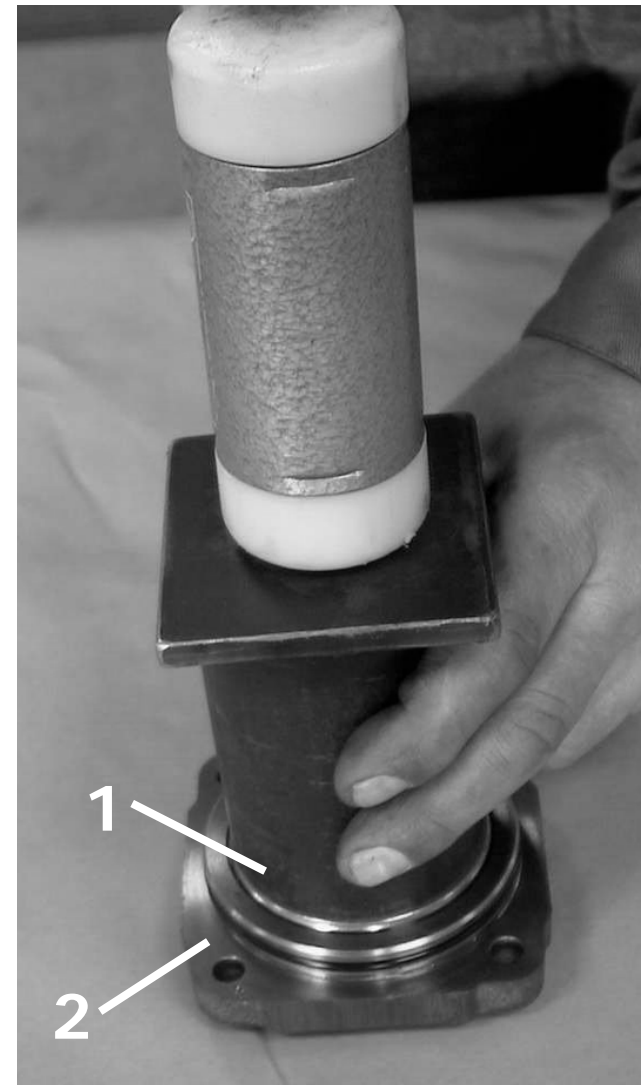

CF 2 - Montagem

Montar o Retentor (1) na Tampa Com Furo (2).

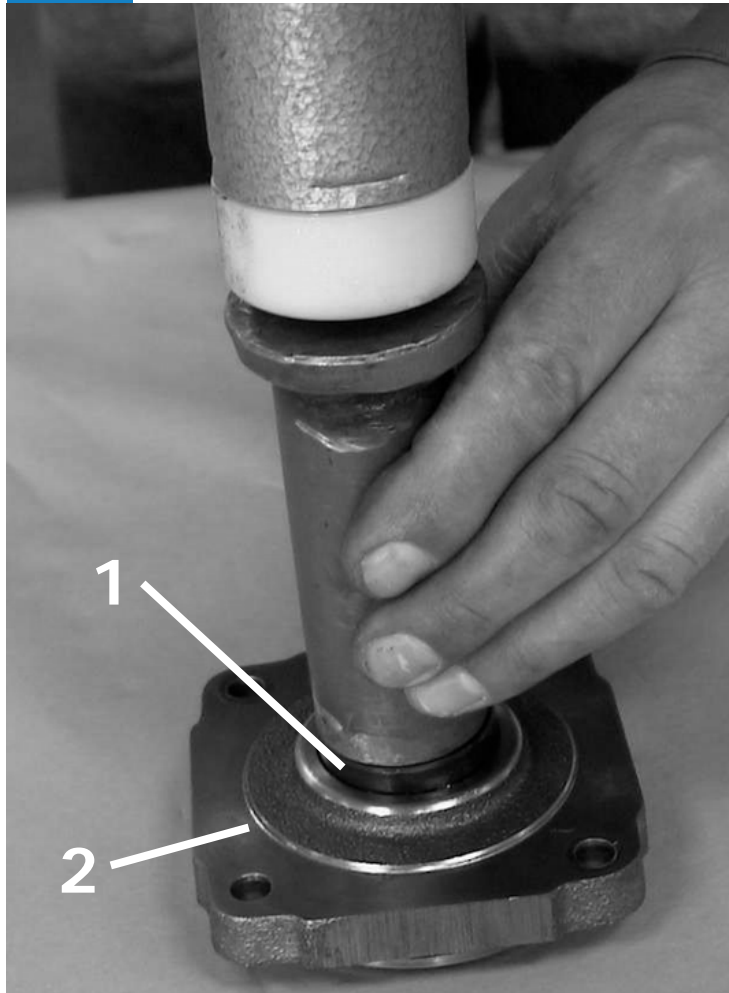

Montar o Anel O-Ring (1).

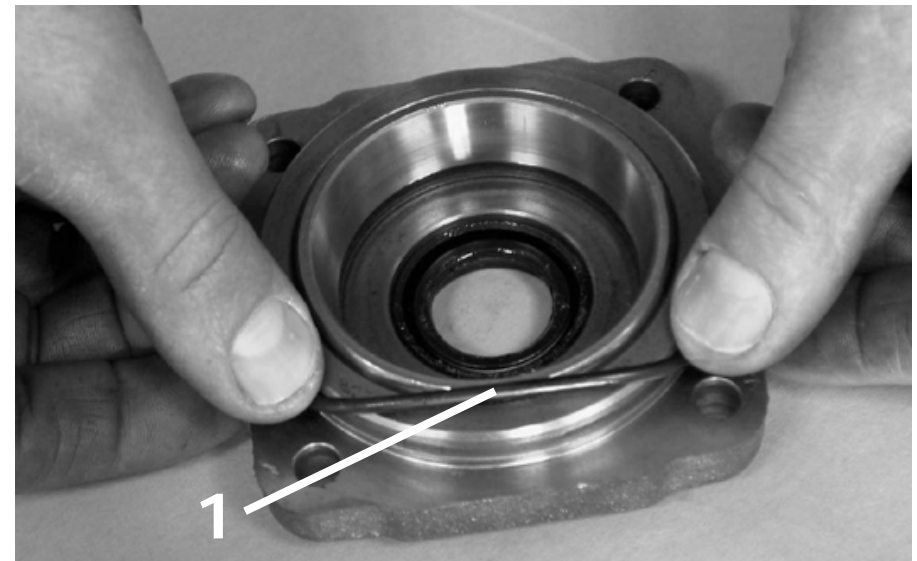

CF 2 - Montagem

Montar o Rolamento (1).

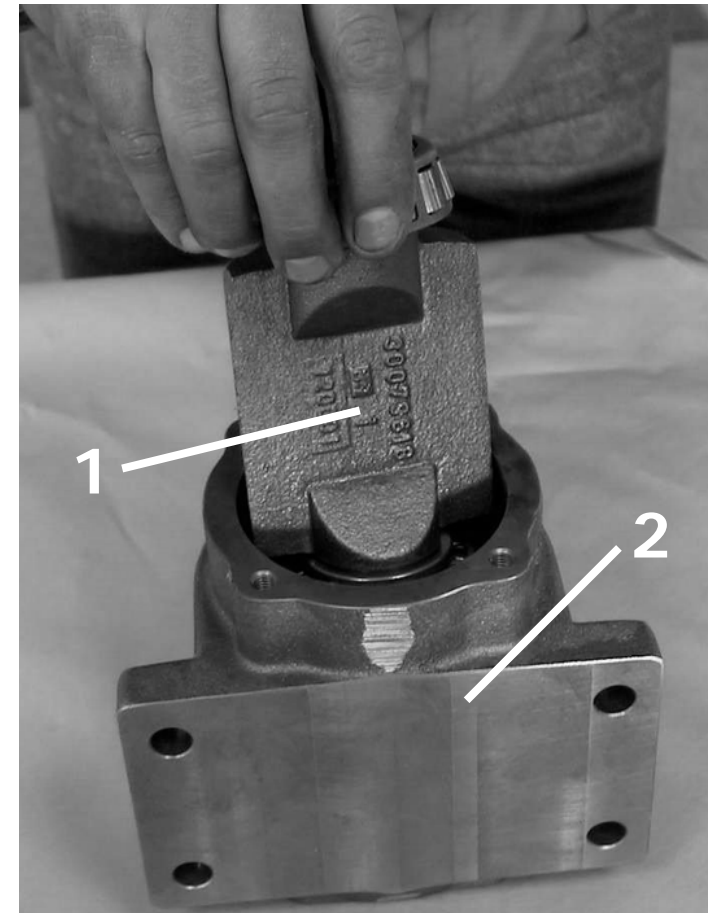

Colocar o Eixo Excêntrico (1) na Carcaça (2).

CF 2 - Montagem

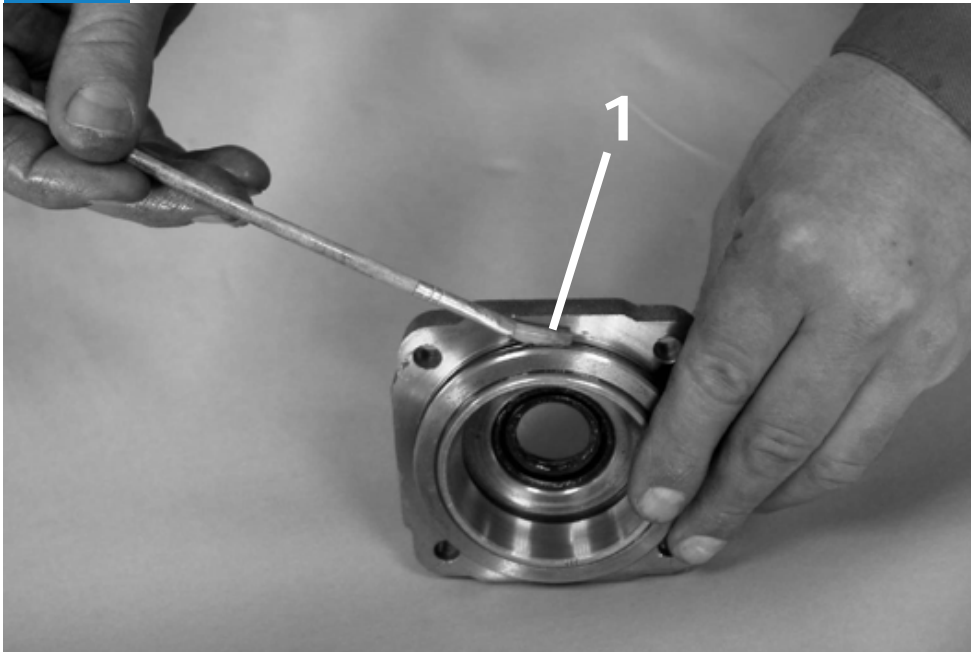

Lubrificar o Anel O-Ring (1) com graxa.

Montar a Tampa Com Furo (1)
na Carcaça do Excêntrico (2).

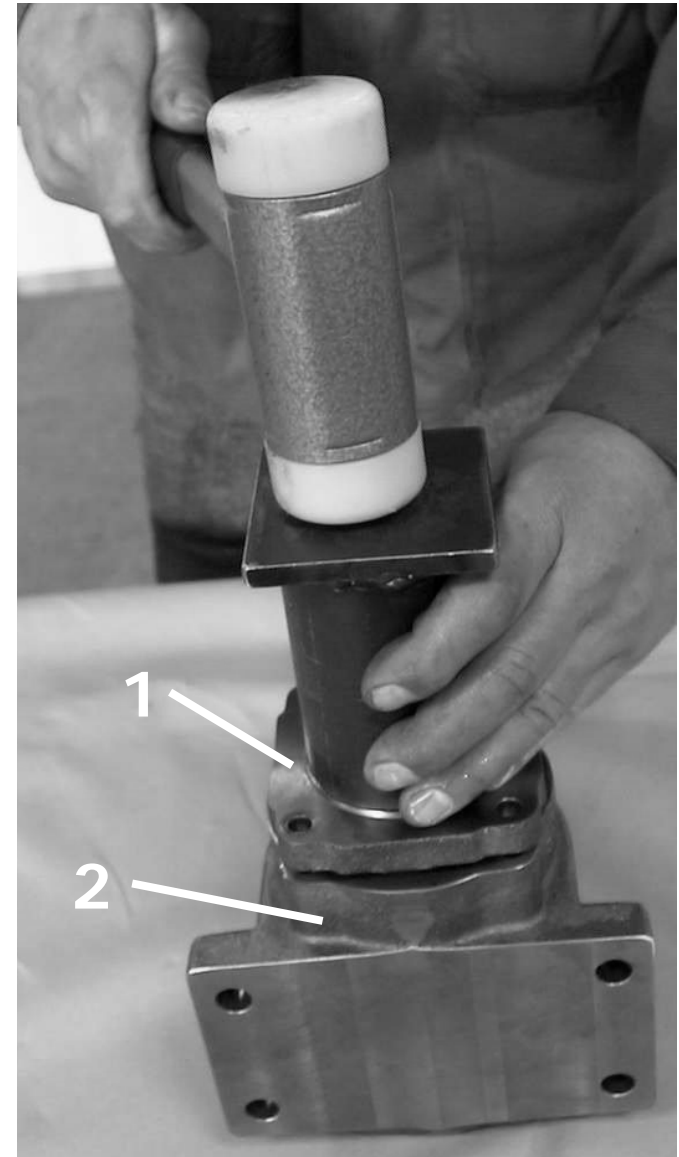

CF 2 - Montagem

Fixar a Tampa Com Furo (1)
com 2 Parafusos (2).

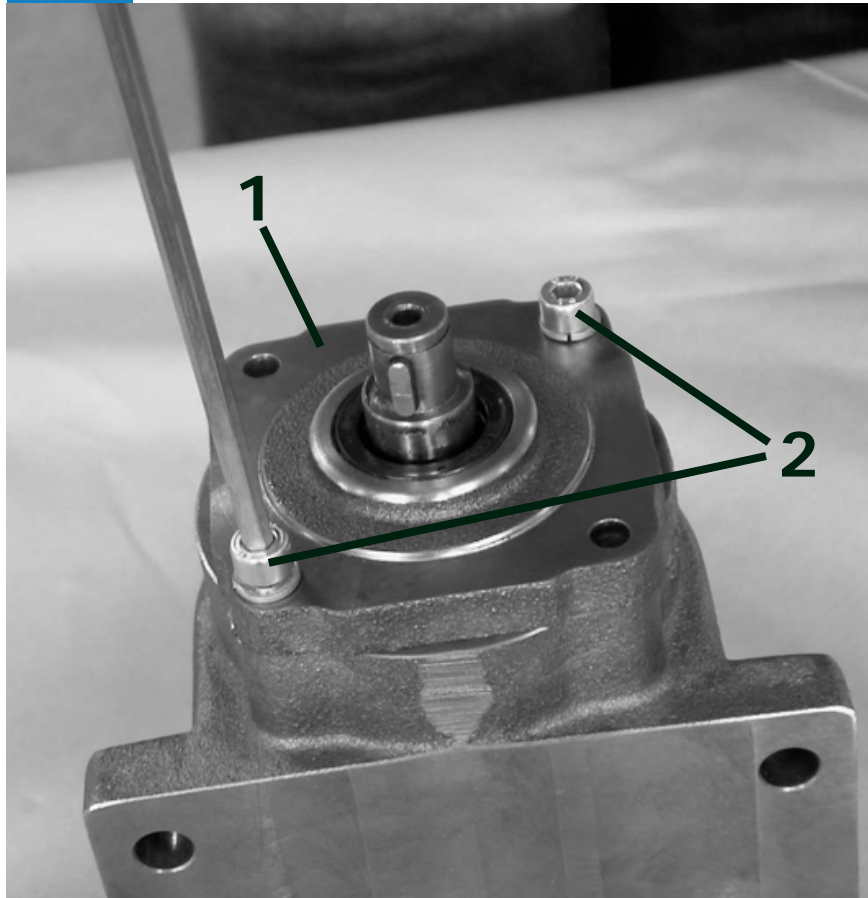

Montar a Polia (1) no Eixo Excêntrico (2).

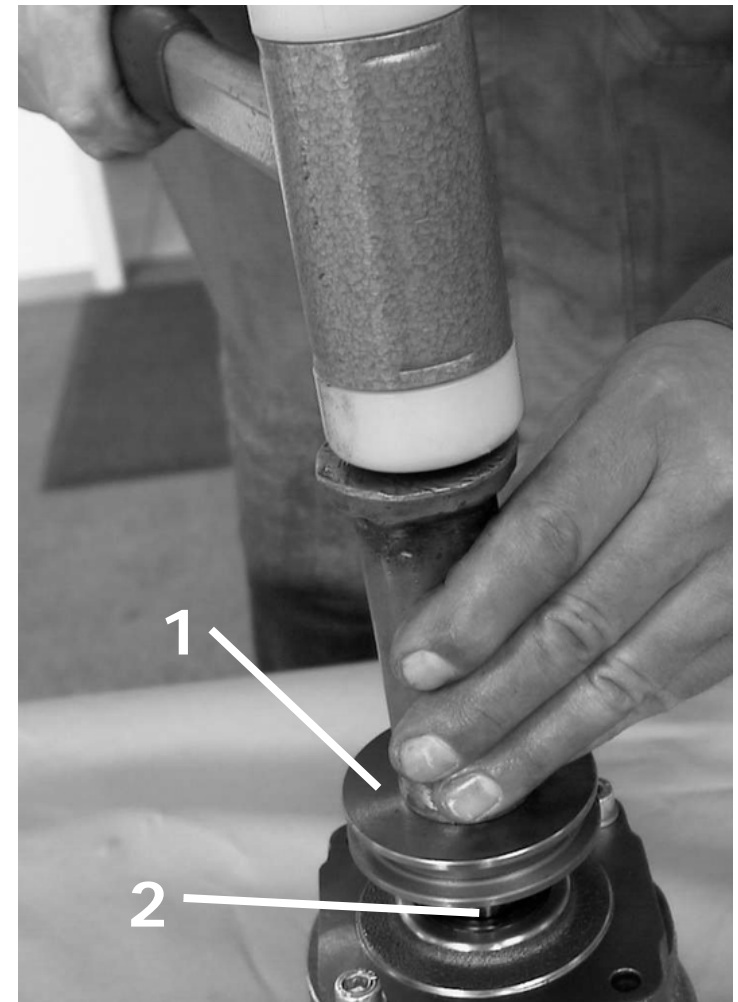

CF 2 - Montagem

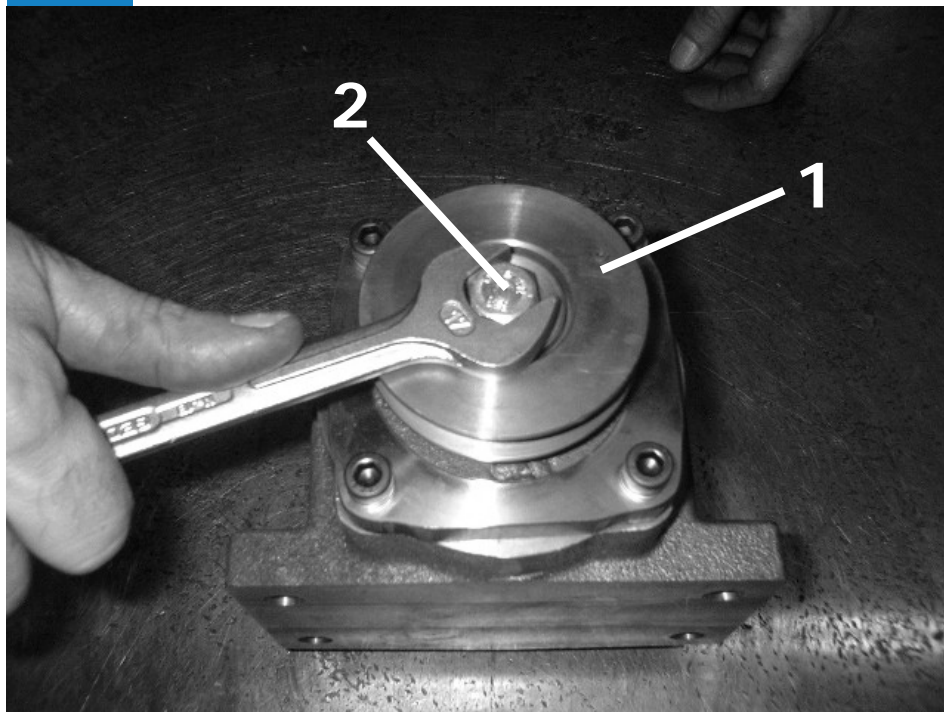

Fixar a Polia (1) com o Parafuso (2). O Parafuso deve ter um furo passante.



Eliminar a folga axial do Conjunto Excêntrico utilizando um batente apropriado.

CF 2 - Montagem

Bater a Pista Externa do Rolamento para eliminar a Folga Axial do Conjunto Excêntrico.



Medir a altura da Tampa Sem Furo (1) já com a Junta de Vedação (2) utilizando um Paquímetro de Profundidade (3) assim como mostrado na foto.

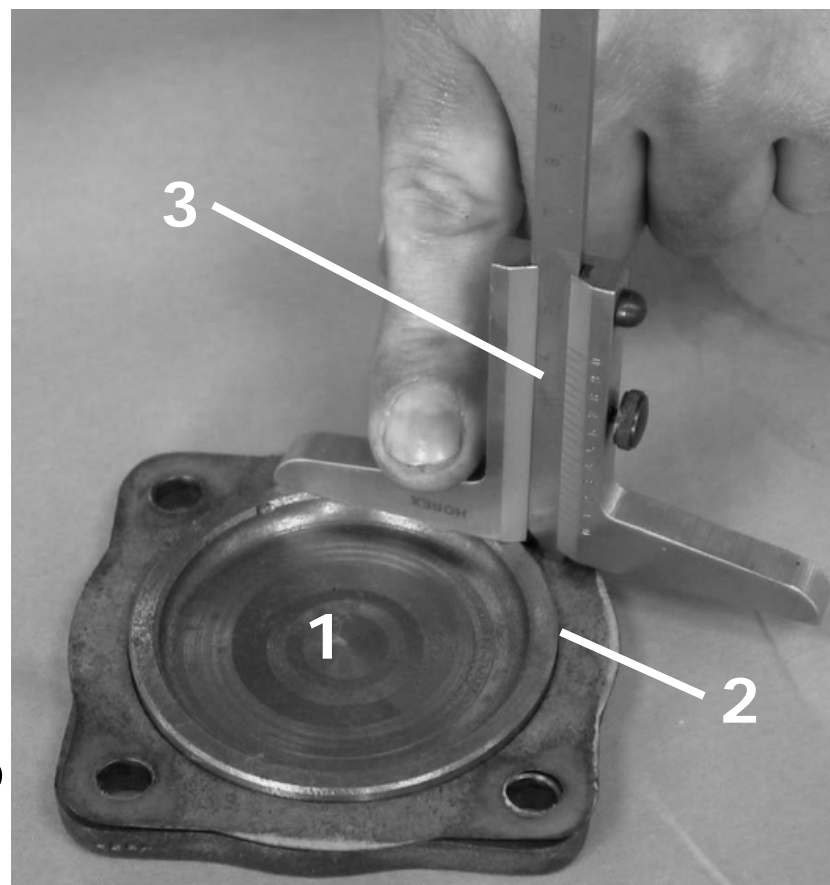

CF 2 - Montagem

Medir a altura entre a Carcaça do Excêntrico (2) e a Pista Externa do Rolamento (1).

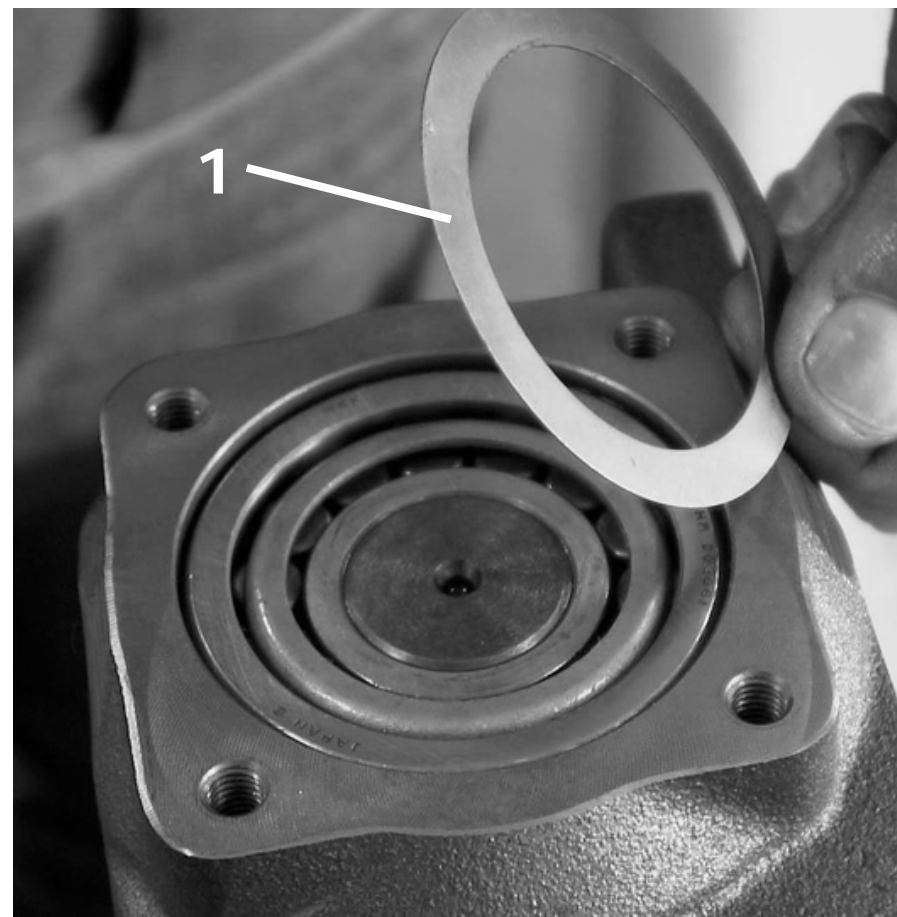
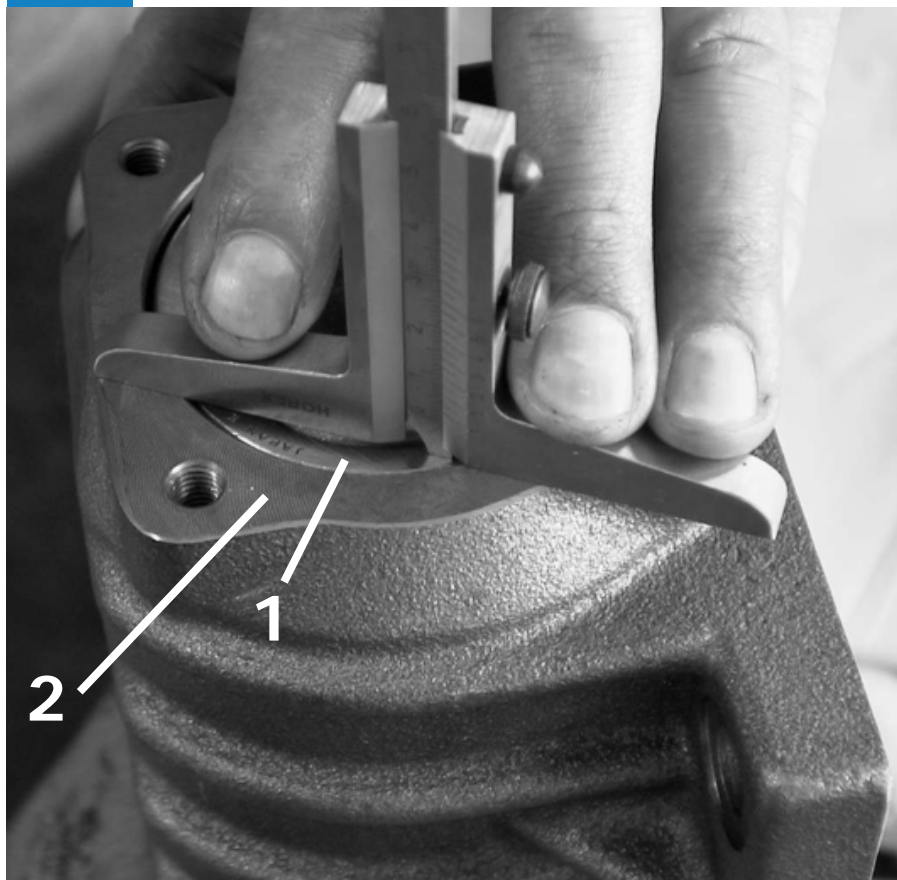

Ajustar a Folga Axial utilizando os Anéis de Afastamento (1). A Folga Axial deve ser de 0,4mm.

CF 2 - Montagem

Montar a Tampa Sem Furo (1).

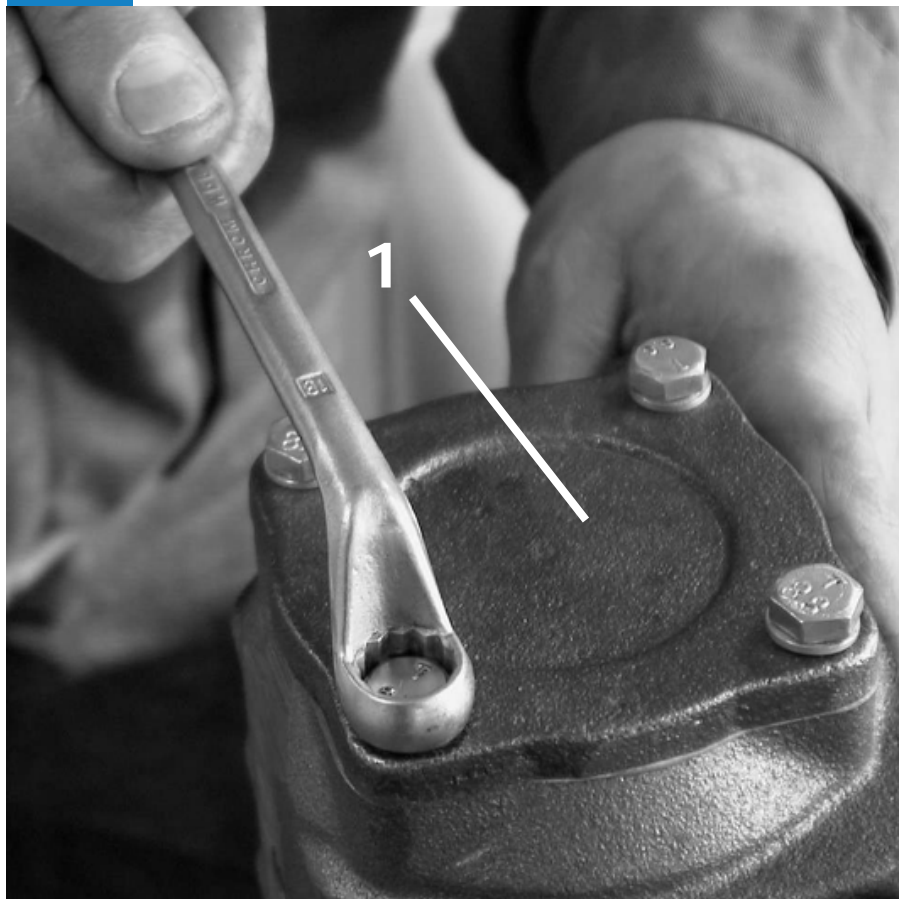

Com leves batidas na Polia (1)
empurrar o Eixo Excêntrico para atrás.

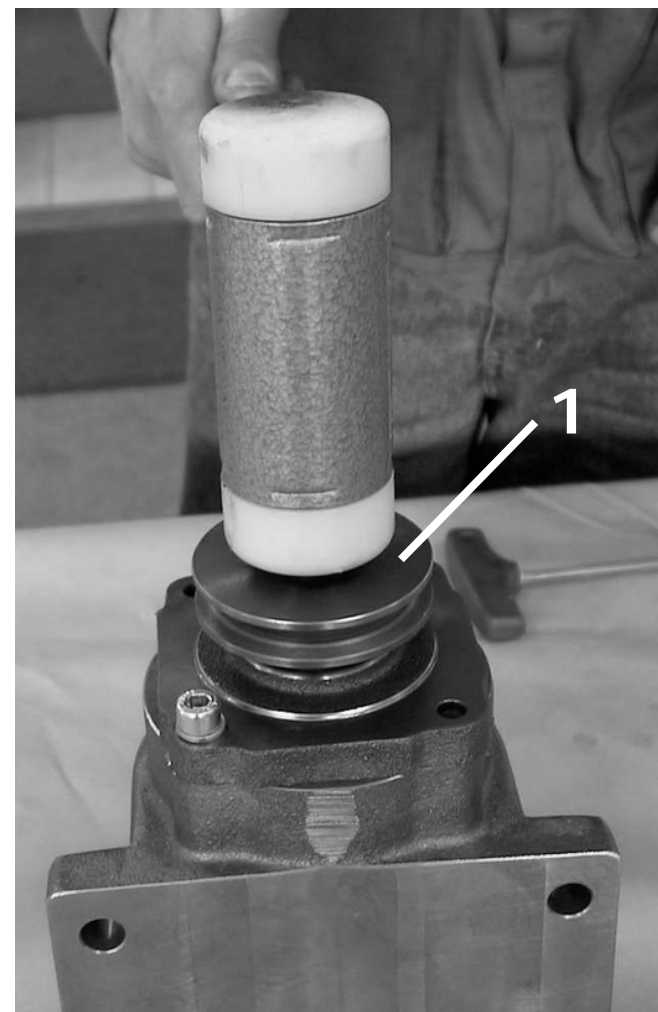

CF 2 - Montagem



Verificar novamente a folga axial do Eixo Excêntrico.

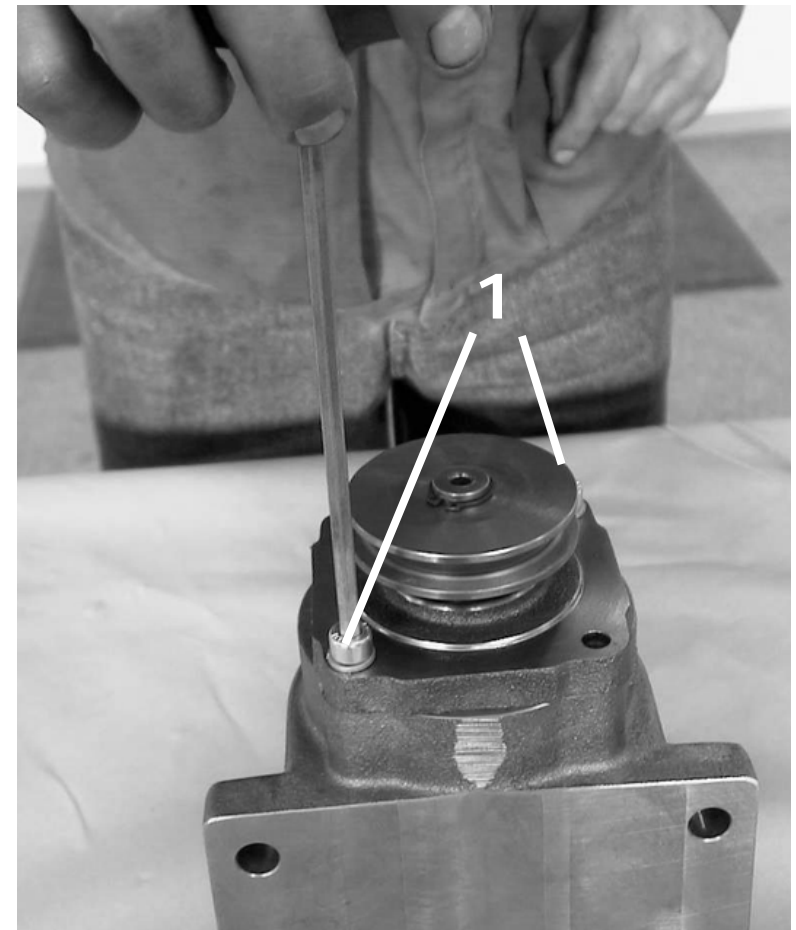

Soltar os Parafusos (1).

CF 2 - Montagem

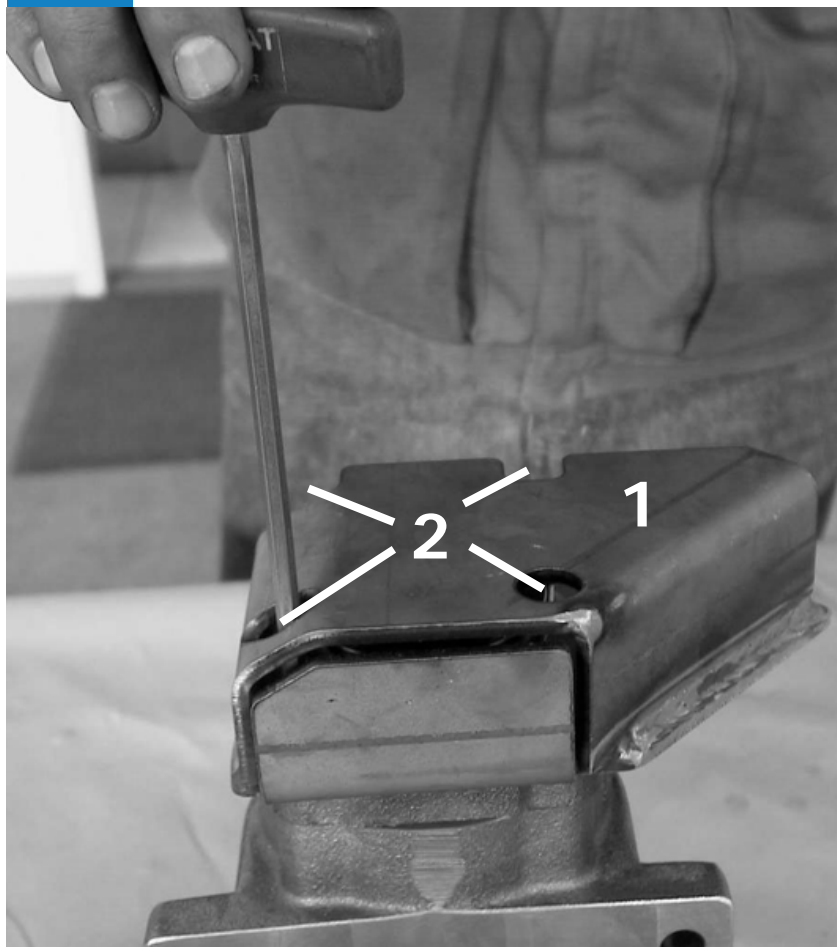

Fixar a Proteção da Polia (1) utilizando os 4 Parafusos e Arruelas de Pressão (2).

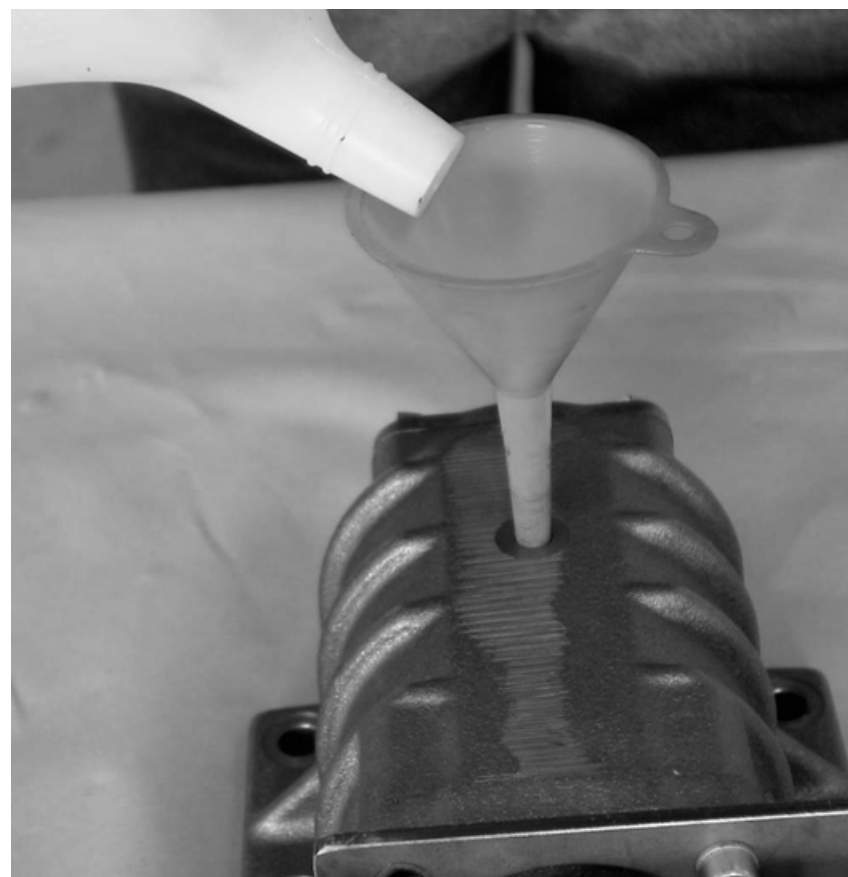

Colocar o óleo assim como especificado no Manual de Operação e Manutenção.

CF 2 - Montagem

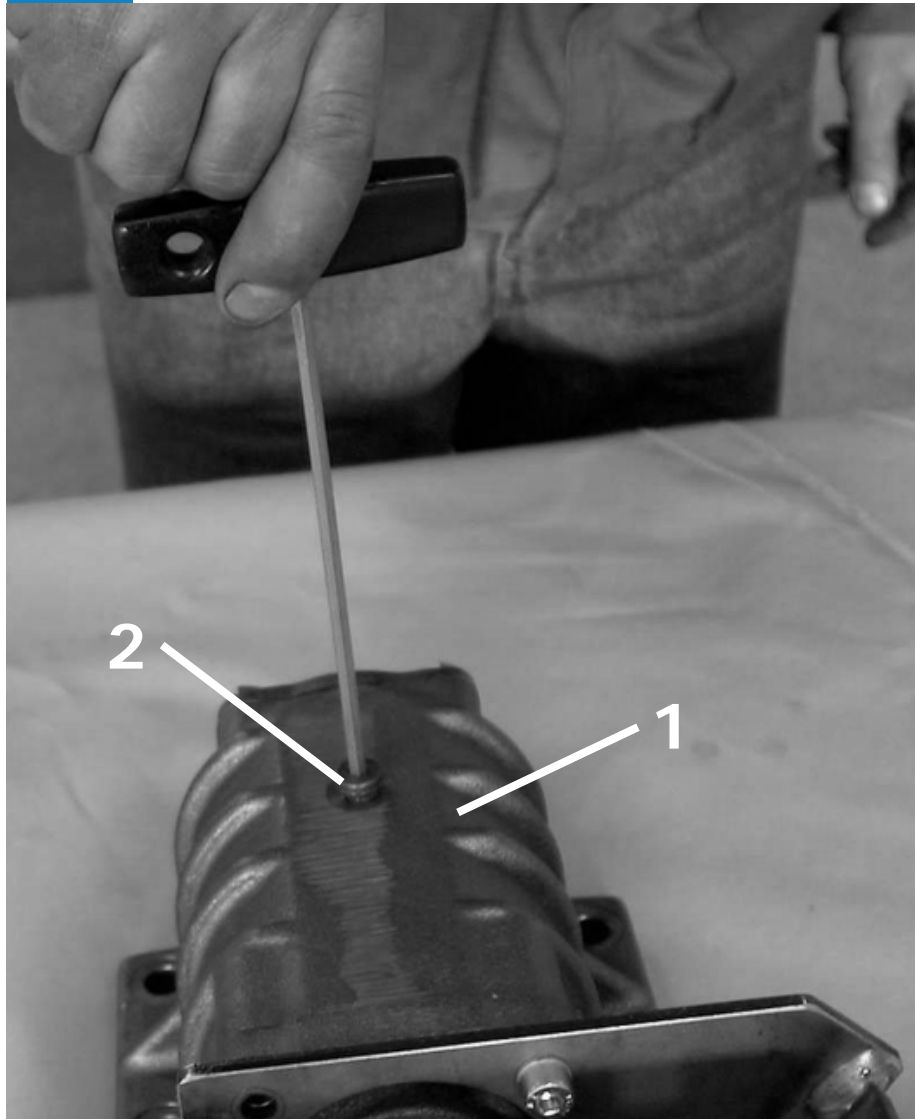

Fechar a Carcaça do Excêntrico (1)
com um Tampão de Óleo novo (2).

